

PRORIL

60 Hz

Designed for continuous operations, excellent performance and easy maintenance, PRORIL Tank series pumps have proven their reliability and durability in demanding areas like construction, mining, tunneling, quarries, industries and rental applications.

Dewatering Pump

TANK 322

High Chrome Dewatering Pump



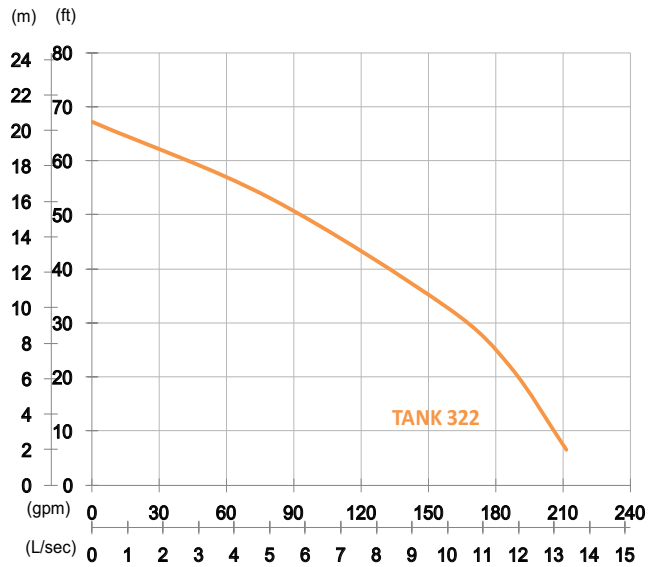

Shaft Speed : 3450 rpm

Outlet : 80mm, 3in

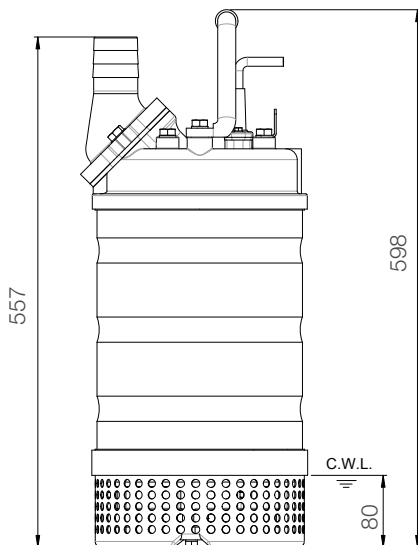
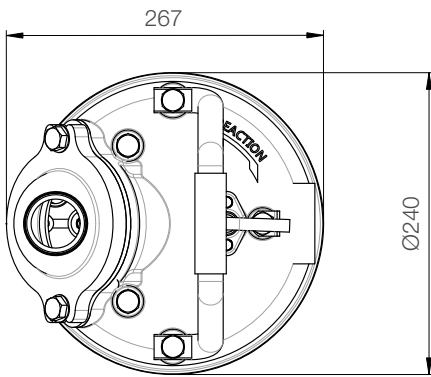

unit : mm

Weight : 35kg / 77 lbs

| OUTPUT | HEAD | FLOW |
|--------|-------------------|-------------------------|
| 2.2 kW | Rated : 10m, 33ft | Rated : 10 L/s, 159 gpm |
| 3 HP | Max : 20.5m, 67ft | Max : 13.3 L/s, 211 gpm |

| | | |
|-------------------------|-------------------------------------|--------------------------|
| Pump Type | Electric Submersible Pumps | |
| | 3-Phase | |
| Motor | Type | Induction Motor |
| | Poles | 2 Pole |
| | Insulation | Class F |
| | Protector | Circle Thermal Protector |
| | Starter | D.O.L. |
| Lubricant | Food Grade (ISO VG32) | |
| Impeller Type | Opened | |
| Shaft Seal | Double Mechanical Seal | |
| | Silicon Carbide VS Ceramic / Carbon | |
| Bearings | C3 Shielded ball bearings | |
| Cable | PVC (CSA Certified) / H07RN-F | |
| | 10m (33ft) or longer upon request. | |
| Materials | Pump Casing | Gray Iron |
| | Impeller | Chromium Iron |
| | Motor Frame | Stainless Steel |
| | Motor Shaft | Stainless Steel |
| | Strainer | Stainless Steel |
| Max. Liquid Temperature | 40°C (104°F) | |
| Max. Submersion Depth | 20m (66ft) | |
| pH Range | pH 5 - pH 8 | |