

# PRORIL

60 Hz

Rugged, reliable and cost effective, the Titan series pumps deliver excellent performance and serve a wide range of tough dewatering applications like mines, construction site, rental applications and other demanding industries.

**Dewatering Pump**

## **TITAN 455**

Heavy Duty Dewatering Pump



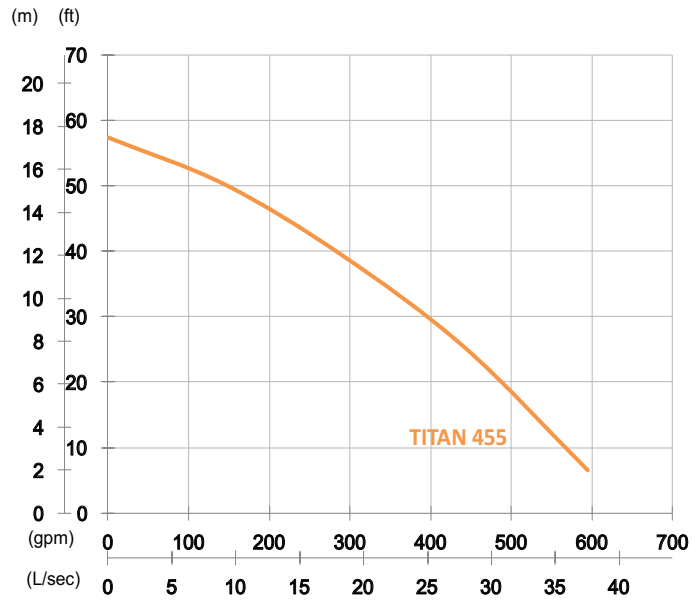

Shaft Speed : 1750 rpm

Outlet : 100mm, 4in

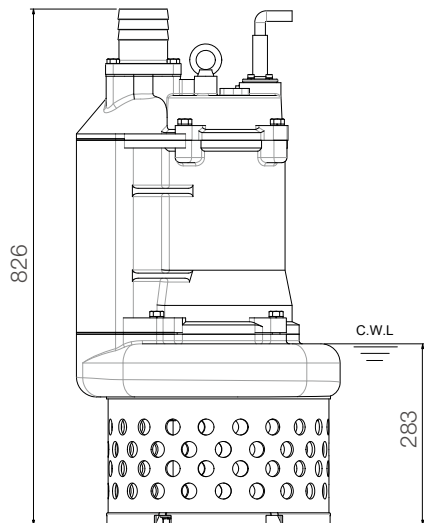
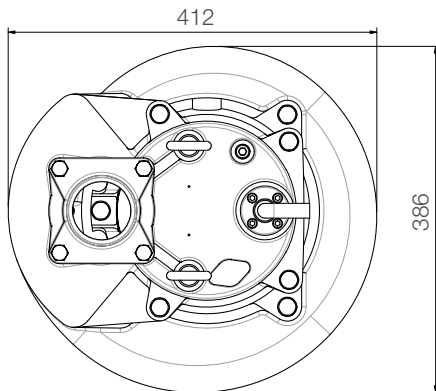

unit : mm

Weight : 129kg / 284 lbs

OUTPUT	HEAD	FLOW
5.5 kW	Rated : 12m, 39ft	Rated : 18.3 L/s, 291 gpm
7.5 HP	Max : 17.5m, 57ft	Max : 37.5 L/s, 594 gpm

Pump Type		Electric Submersible Pumps
		3-Phase
Motor	Type	Induction Motor
	Poles	4 Pole
	Insulation	Class F
	Protector	Circle Thermal Protector
	Starter	D.O.L.
Lubricant		Food Grade (ISO VG32)
Impeller Type		Opened
Shaft Seal		Double Mechanical Seal
		Silicon Carbide VS Ceramic / Carbon
Bearings		C3 Shielded ball bearings
Cable		PVC (CSA Certified) / H07RN-F
		10m (33ft) or longer upon request.
Materials	Pump Casing	Ductile Iron
	Impeller	Chromium Iron
	Motor Frame	Gray Iron
	Motor Shaft	Stainless Steel
	Strainer	Carbon Steel
Max. Liquid Temperature		40°C (104°F)
Max. Submersion Depth		20m (66ft)
pH Range		pH 5 - pH 8