

PRORIL

50 Hz

Designed for light weight, excellent performance, low energy consumption, and easy maintenance, PRORIL residue pumps can pump down to a low water level at 1/16" (2mm), which is ideal for pumping flat surface such as basements, parking garages, pools, spas and etc.



Handy and Residue Pump

SMART LITE BASE 400

Residue Pump

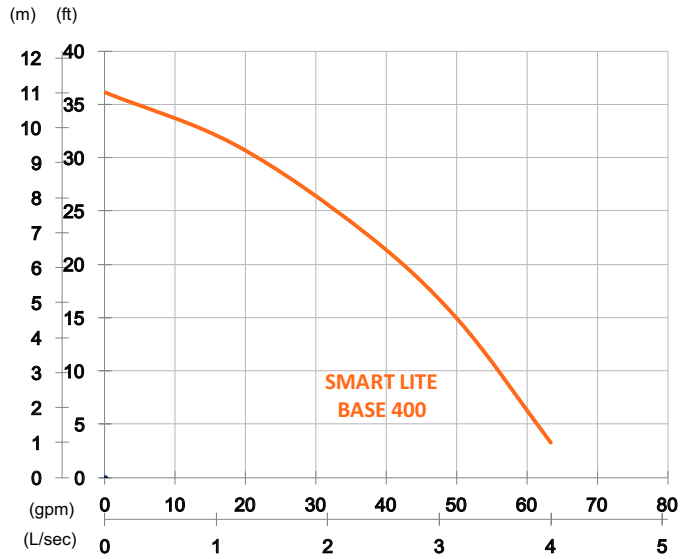

Shaft Speed : 2850 rpm

Outlet : 50mm, 2in

OUTPUT	HEAD	FLOW
0.4 kW	Rated : 7m, 23ft	Rated : 2.3 L/s, 37 gpm
0.5 HP	Max : 11m, 36ft	Max : 4 L/s, 63 gpm

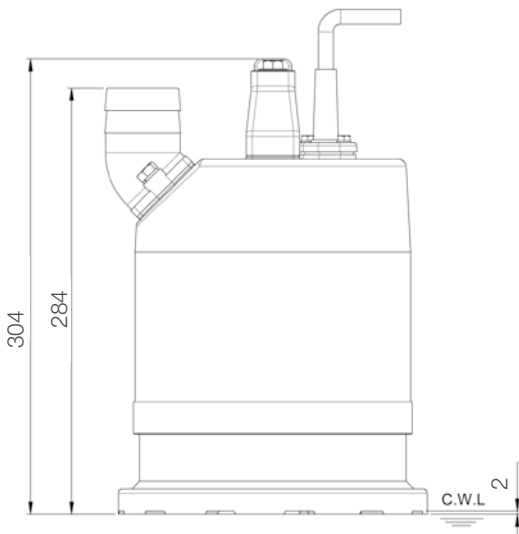
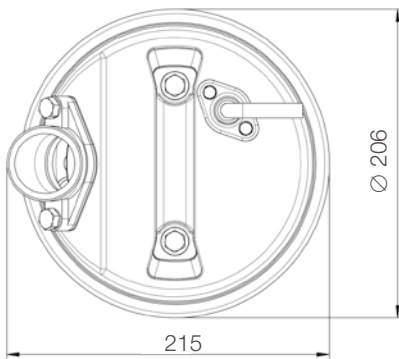

unit : mm

Weight : 11kg / 24 lbs

Pump Type		Electric Submersible Pumps
		1-Phase
Motor	Type	Induction Motor
	Poles	2 Pole
	Insulation	Class F
	Protector	Miniature Thermal Protector
	Starter Method	Capacitor-Run
Lubricant		Food Grade (ISO VG32)
Impeller Type		Semi-VorteX
Shaft Seal		Double Mechanical Seal
		Silicon Carbide VS Ceramic / Carbon
Bearings		C3 Shielded ball bearings
Cable		PVC (CSA Certified) / H07RN-F
		6m (20ft) or longer upon request.
Materials	Pump Casing	Gray Iron
	Impeller	Synthetic Polymers
	Motor Frame	Aluminum
	Motor Shaft	Stainless Steel
	Outer Case	Aluminum
	Bottom Plate	Synthetic Rubber
Max. Liquid Temperature		40°C (104°F)
Max. Submersion Depth		20m (66ft)
pH Range		pH 5 - pH 8