

PRORIL

50 Hz

Rugged, reliable and cost effective, the Titan series pumps deliver excellent performance and serve a wide range of tough dewatering applications like mines, construction site, rental applications and other demanding industries.

Dewatering Pump

TITAN 6150

Heavy Duty Dewatering Pump



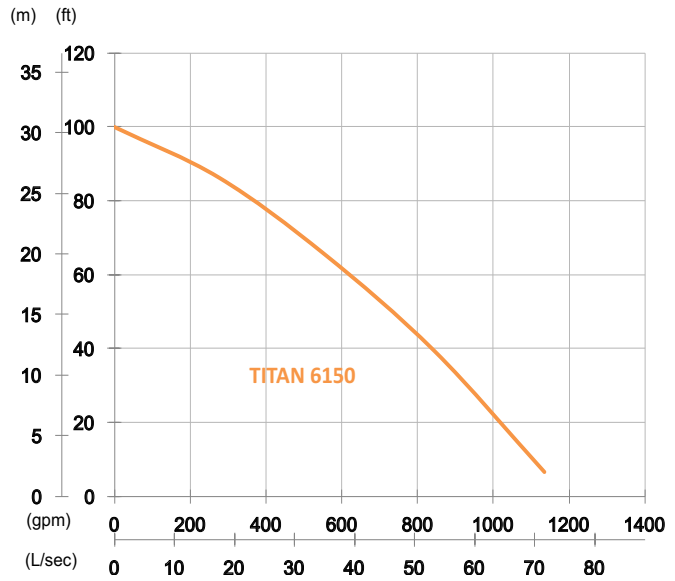

Shaft Speed : 1450 rpm

Outlet : 150mm, 6in

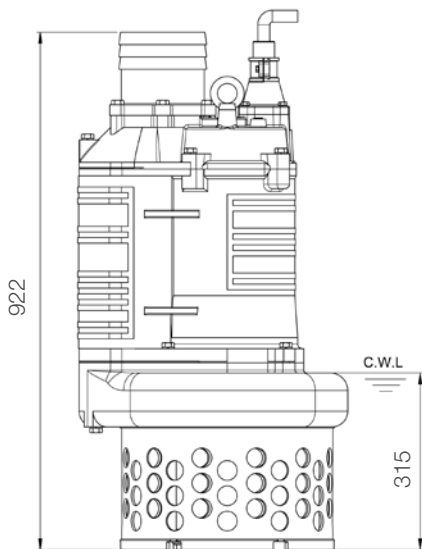
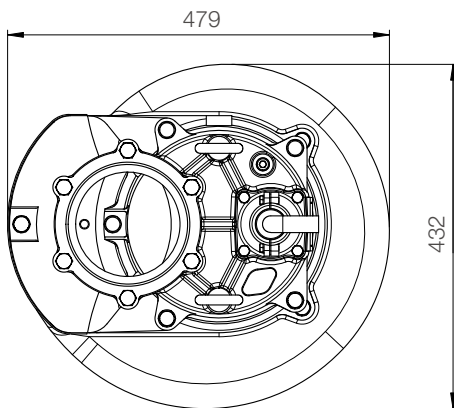

unit : mm

Weight : 204kg / 450 lbs

| OUTPUT | HEAD | FLOW |
|--------|--------------------|--------------------------|
| 15 kW | Rated : 20m, 66ft | Rated : 35 L/s, 554 gpm |
| 20 HP | Max : 30.5m, 100ft | Max : 71.6 L/s, 1135 gpm |

| | | |
|-------------------------|-------------------------------------|--------------------------|
| Pump Type | Electric Submersible Pumps | |
| | 3-Phase | |
| Motor | Type | Induction Motor |
| | Poles | 4 Pole |
| | Insulation | Class F |
| | Protector | Circle Thermal Protector |
| | Starter | D.O.L. |
| Lubricant | Food Grade (ISO VG32) | |
| Impeller Type | Opened | |
| Shaft Seal | Double Mechanical Seal | |
| | Silicon Carbide VS Ceramic / Carbon | |
| Bearings | C3 Shielded ball bearings | |
| Cable | PVC (CSA Certified) / H07RN-F | |
| | 10m (33ft) or longer upon request. | |
| Materials | Pump Casing | Ductile Iron |
| | Impeller | Chromium Iron |
| | Motor Frame | Gray Iron |
| | Motor Shaft | Stainless Steel |
| | Strainer | Carbon Steel |
| Max. Liquid Temperature | 40°C (104°F) | |
| Max. Submersion Depth | 20m (66ft) | |
| pH Range | pH 5 - pH 8 | |