

PRORIL

60 Hz

Designed for light weight, excellent performance, low energy consumption, and easy maintenance, PRORIL submersible handy pumps serve a wide range of pumping applications on utility, construction, industrial, and municipal job sites.

Handy and Residue Pump

SAVVY 100

Handy Pump



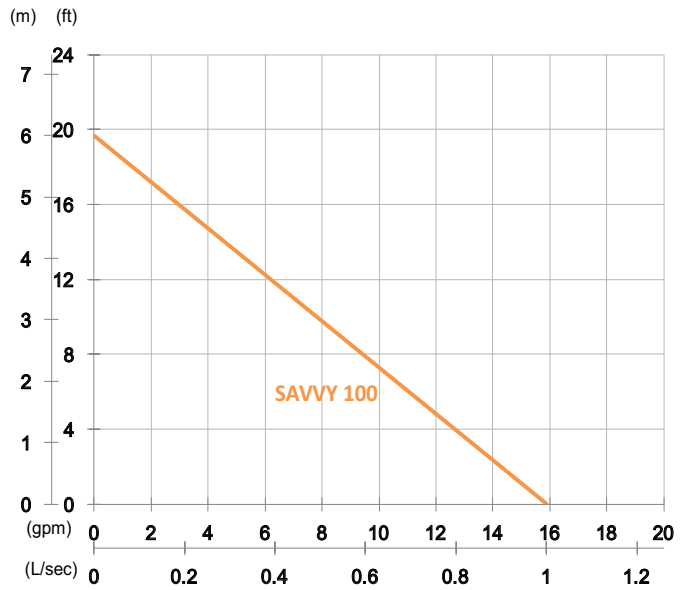

Shaft Speed : 3450 rpm

Outlet : 20mm, 0.75in

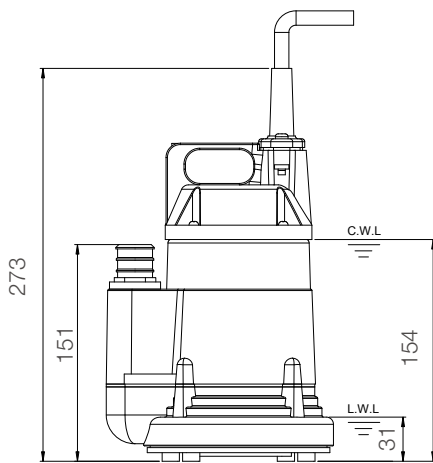
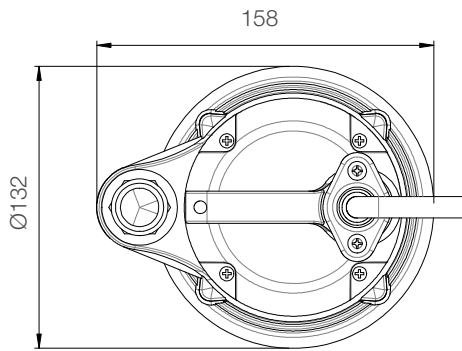

unit : mm

Weight : 3kg / 7 lbs

OUTPUT	HEAD	FLOW
0.1 kW	Rated : 2m, 7ft	Rated : 0.7 L/s, 11 gpm
0.13 HP	Max : 6m, 20ft	Max : 1 L/s, 16 gpm

Solid Passage : 6mm, 0.2in

Pump Type	Electric Submersible Pumps	
	1-Phase	
Motor	Type	Induction Motor
	Poles	2 Pole
	Insulation	Class F
	Protector	Miniature Thermal Protector
	Starter	Capacitor-Run
Lubricant	Food Grade (ISO VG115)	
Impeller Type	Opened	
Shaft Seal	Oil Seal	
Bearings	Shielded ball bearings	
Cable	PVC (CSA Certified) / H05RN-F	
	3m (10ft) or longer upon request.	
Materials	Pump Casing	Aluminum
	Impeller	Synthetic Polymers
	Motor Frame	Aluminum
	Motor Shaft	Carbon Steel
Max. Liquid Temperature	40°C (104°F)	
Max. Submersion Depth	5m (16ft)	
pH Range	pH 5 - pH 8	