

PRORIL

50 Hz

Designed for light weight, excellent performance, low energy consumption, and easy maintenance, PRORIL submersible handy pumps serve a wide range of pumping applications on utility, construction, industrial, and municipal job sites.

Handy and Residue Pump

SAVVY 600

Handy Pump



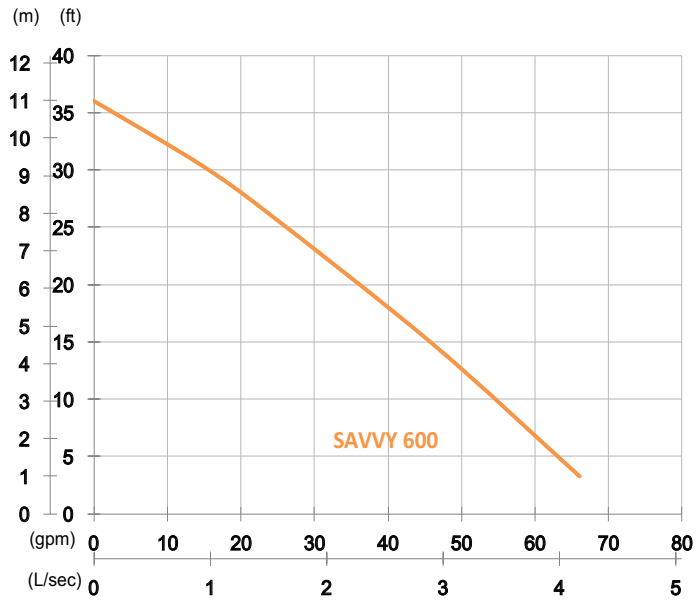

Shaft Speed : 2850 rpm

Outlet : 50mm, 2in

OUTPUT	HEAD	FLOW
0.55 kW	Rated : 8m, 26ft	Rated : 1.5 L/s, 24 gpm
0.75 HP	Max : 11m, 36ft	Max : 4.2 L/s, 66 gpm

Solid Passage : 6 mm, 0.2 in

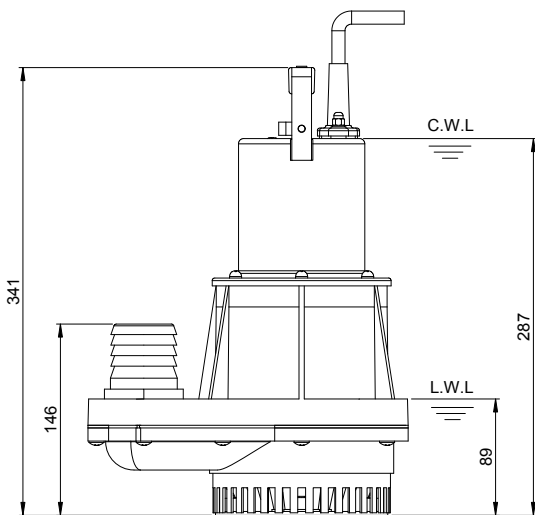
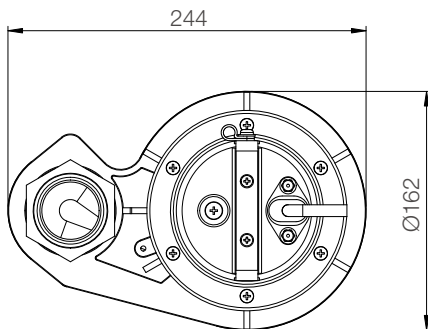

unit : mm

Weight : 6kg / 13 lbs

Pump Type	Electric Submersible Pumps	
	1-Phase	
Motor	Type	Induction Motor
	Poles	2 Pole
	Insulation	Class F
	Protector	Miniature Thermal Protector
	Starter	Capacitor-Run
Lubricant	Food Grade (ISO VG115)	
Impeller Type	Vortex	
Shaft Seal	Single Mechanical Seal	
	Ceramic / Carbon	
Bearings	C3 Shielded ball bearings	
Cable	PVC (CSA Certified) / H07RN-F	
	6m (20ft) or longer upon request.	
Materials	Pump Casing	Synthetic Polymers
	Impeller	Synthetic Polymers
	Motor Frame	Stainless Steel
	Motor Shaft	Stainless Steel
	Strainer	Synthetic Polymers
Max. Liquid Temperature	40°C (104°F)	
Max. Submersion Depth	10m (33ft)	
pH Range	pH 5 - pH 8	