

PRORIL

60 Hz

Rugged, reliable and cost effective, the Titan series pumps deliver excellent performance and serve a wide range of tough dewatering applications like mines, construction site, rental applications and other demanding industries.

Dewatering Pump

TITAN 6150L

Heavy Duty Dewatering Pump



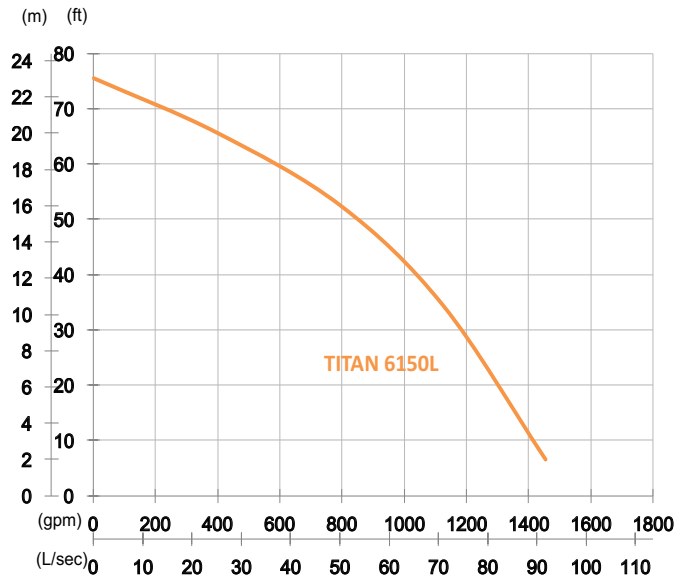

Shaft Speed : 1750 rpm

Outlet : 150mm, 6in

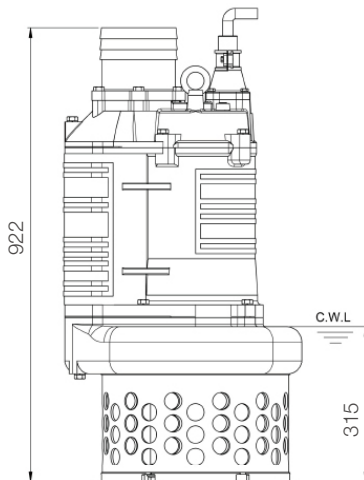
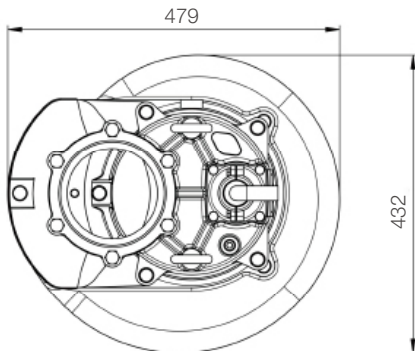

unit : mm

Weight : 205kg / 452 lbs

OUTPUT	HEAD	FLOW
15 kW	Rated : 16m, 52ft	Rated : 50 L/s, 793 gpm
20 HP	Max : 23m, 75ft	Max : 91.7 L/s, 1453 gpm

Solid Passage : 35mm, 1.4in

Pump Type		Electric Submersible Pumps
		3-Phase
Motor	Type	Induction Motor
	Poles	4 Pole
	Insulation	Class F
	Protector	Circle Thermal Protector
	Starter	D.O.L.
Lubricant		Food Grade (ISO VG32)
Impeller Type		Opened
Shaft Seal		Double Mechanical Seal
		Silicon Carbide VS Ceramic / Carbon
Bearings		C3 Shielded ball bearings
Cable		PVC (CSA Certified) / H07BQ-F
		10m (33ft) or longer upon request.
Materials	Pump Casing	Ductile Iron
	Impeller	Chromium Iron
	Motor Frame	Gray Iron
	Motor Shaft	Stainless Steel
	Strainer	Carbon Steel
Max. Liquid Temperature		40°C (104°F)
Max. Submersion Depth		20m (66ft)
pH Range		pH 5 - pH 8