

# PRORIL

50 Hz

GOSPIN Series, the classical drainage pumps with strainer and rigid casting are engineered for various effluent pumping applications in commercial and industrial sectors.

**Sewage Pump**

## **GOSPIN 315**

Drainage Pump



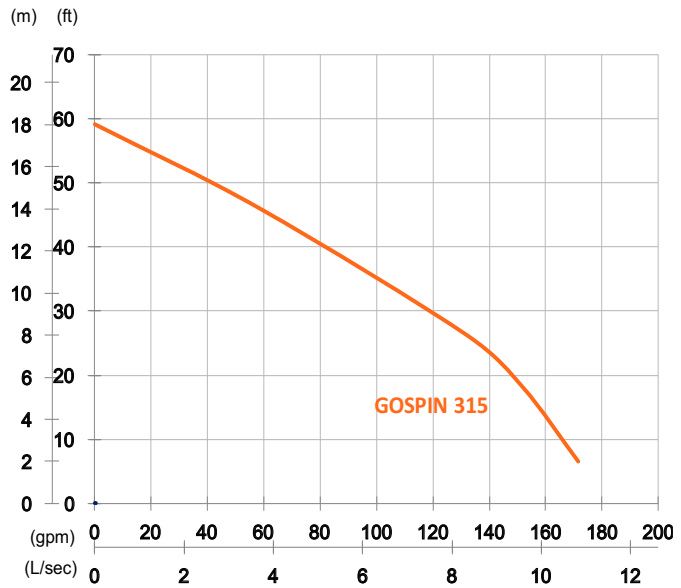

Shaft Speed : 2850 rpm

Outlet : 80mm, 3in

OUTPUT	HEAD	FLOW
1.5 kW	Rated : 8m, 26ft	Rated : 8.3 L/s, 132 gpm
2 HP	Max : 18m, 59ft	Max : 10.8 L/s, 172 gpm

Solid Passage : 7 mm, 0.3 in

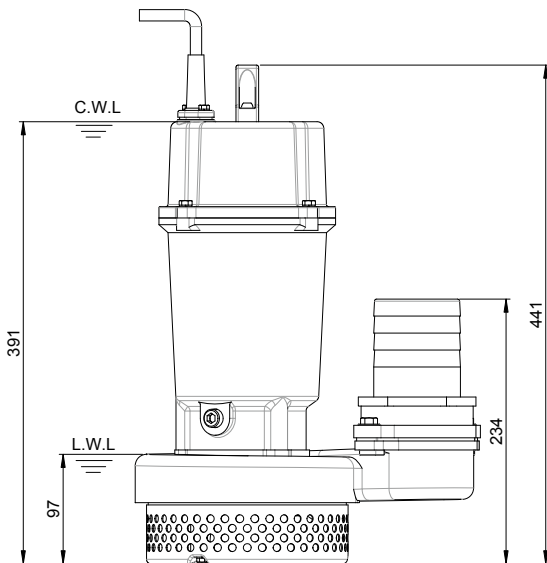
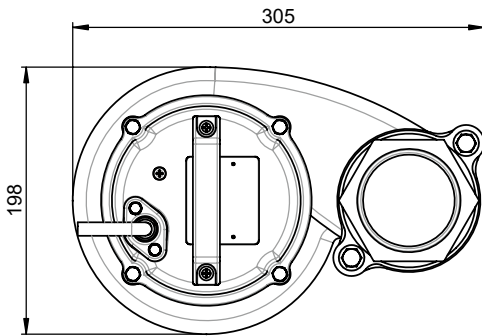

unit : mm

Weight : 23kg / 51 lbs

Pump Type	Electric Submersible Pumps	
	1-Phase, 3-Phase	
Motor	Type	Induction Motor
	Poles	2 Pole
	Insulation	Class F
	Protector	Circle Thermal Protector
Starter	1-Phase · Capacitor-Run, 3-Phase · D.O.L.	
Lubricant	Food Grade (ISO VG32)	
Impeller Type	Semi-Open	
Shaft Seal	Double Mechanical Seal	
	Silicon Carbide VS Ceramic / Carbon	
Bearings	C3 Shielded ball bearings	
Cable	PVC (CSA Certified) / H07RN-F	
	6m (20ft) or longer upon request.	
Materials	Pump Casing	Gray Iron
	Impeller	Gray Iron
	Motor Frame	Gray Iron
	Motor Shaft	Stainless Steel
Strainer	Stainless Steel	
Max. Liquid Temperature	40°C (104°F)	
Max. Submersion Depth	20m (66ft)	
pH Range	pH 5 - pH 8	
Guide Rail	GRL-03F	