

PRORIL

50 Hz

GOSPIN Series, the classical drainage pumps with strainer and rigid casting are engineered for various effluent pumping applications in commercial and industrial sectors.

Sewage Pump

GOSPIN 437

Drainage Pump



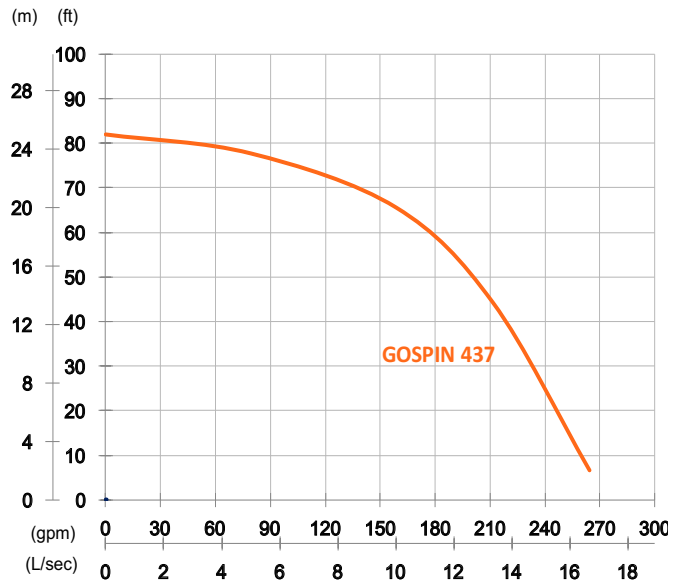

Shaft Speed : 2850 rpm

Outlet : 100mm, 4in

OUTPUT	HEAD	FLOW
3.7 kW	Rated : 20m, 66ft	Rated : 10 L/s, 158 gpm
5 HP	Max : 25m, 82ft	Max : 16.7 L/s, 264 gpm

Solid Passage : 9 mm, 0.4 in

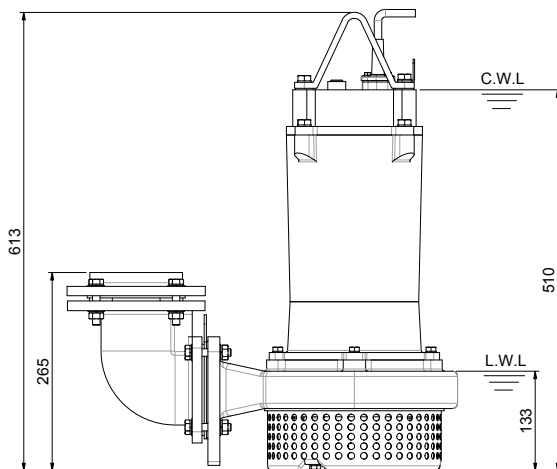
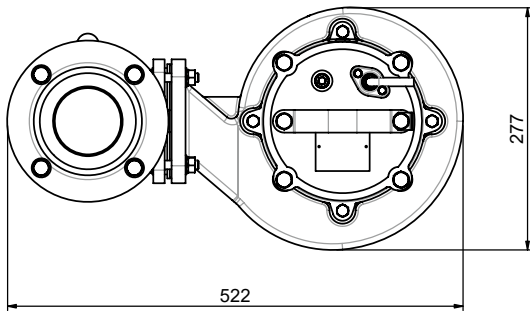

unit : mm

Weight : 56kg / 123 lbs

Pump Type	Electric Submersible Pumps	
	3-Phase	
Motor	Type	Induction Motor
	Poles	2 Pole
	Insulation	Class F
	Protector	Circle Thermal Protector
	Starter	D.O.L.
Lubricant	Food Grade (ISO VG32)	
Impeller Type	Semi-Open	
Shaft Seal	Double Mechanical Seal	
	Silicon Carbide VS Ceramic / Carbon	
Bearings	C3 Shielded ball bearings	
Cable	PVC (OSA Certified) / H07RN-F	
	10m (33ft) or longer upon request.	
Materials	Pump Casing	Gray Iron
	Impeller	Gray Iron
	Motor Frame	Gray Iron
	Motor Shaft	Stainless Steel
	Strainer	Stainless Steel
Max. Liquid Temperature	40°C (104°F)	
Max. Submersion Depth	20m (66ft)	
pH Range	pH 5 - pH 8	
Guide Rail	GRF-04	