

PRORIL

60 Hz

GOMAX Series, these non-clog pumps employ a single-channel enclosed impeller to efficiently and reliably transfer 76mm diameter solids without clogging. GOMAX series pumps are suitable for commercial and industrial wastewater applications.

Sewage Pump

GOMAX 6150

Single Channel Pump



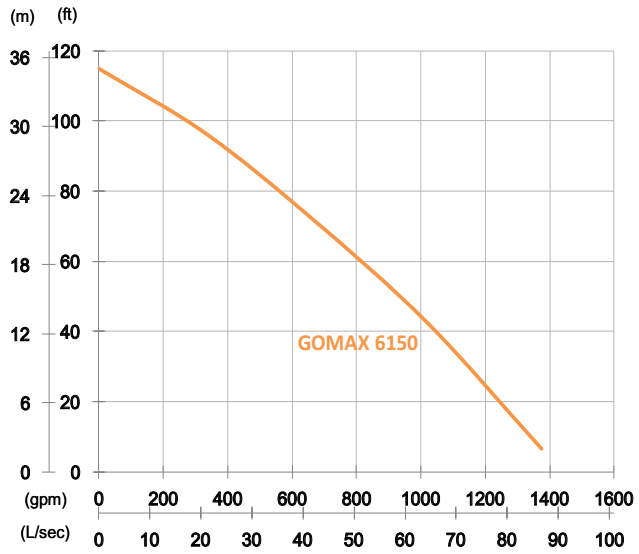

Shaft Speed : 1750 rpm

Outlet : 150mm, 6in

OUTPUT	HEAD	FLOW
15 kW	Rated : 22m, 72ft	Rated : 41.6 L/s, 660 gpm
20 HP	Max : 35m, 115ft	Max : 86.6 L/s, 1373 gpm

Solid Passage : 76mm, 3in

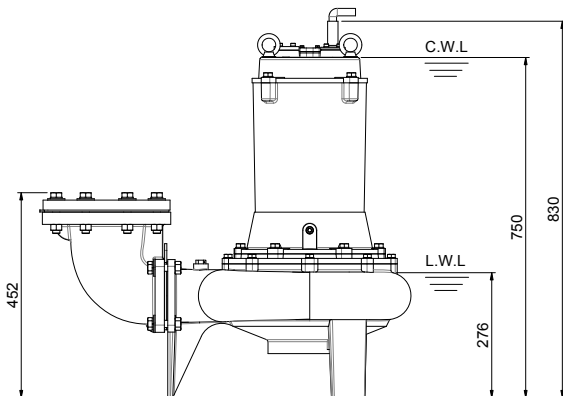
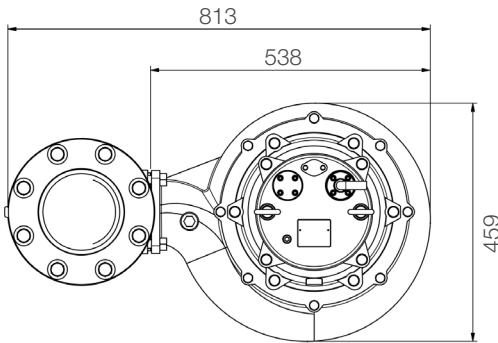

unit : mm

Weight : 186kg / 410 lbs

Pump Type	Electric Submersible Pumps	
	3-Phase	
Motor	Type	Induction Motor
	Poles	4 Pole
	Insulation	Class F
	Protector	Star-Delta • Miniature Thermal Sensors D.O.L. • Circle Thermal Protector
	Starter	Star-Delta , D.O.L.
Lubricant	Food Grade (ISO VG32)	
Impeller Type	Single Channel	
Shaft Seal	Double Mechanical Seal	
	Silicon Carbide VS Ceramic / Carbon	
Bearings	C3 Shielded ball bearings	
Cable	PVC (CSA Certified) / H07RN-F	
	10m (33ft) or longer upon request.	
Materials	Pump Casing	Gray Iron
	Impeller	Gray Iron
	Motor Frame	Gray Iron
	Motor Shaft	Stainless Steel
	Mouth Ring	Copper Alloy
Max. Liquid Temperature	40°C (104°F)	
Max. Submersion Depth	20m (66ft)	
pH Range	pH 5 - pH 8	
Guide Rail	GRN-04	