

PRORIL

60 Hz

GOMAX Series, these non-clog pumps employ a single-channel enclosed impeller to efficiently and reliably transfer 76mm diameter solids without clogging. GOMAX series pumps are suitable for commercial and industrial wastewater applications.

Sewage Pump

GOMAX 655

Single Channel Pump



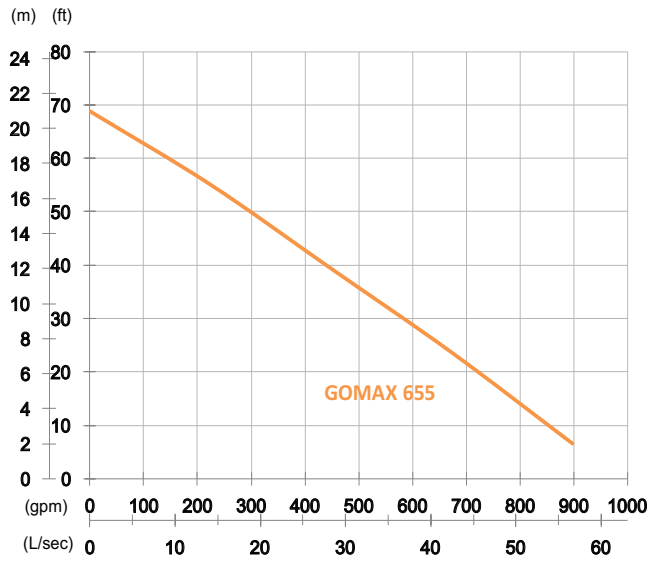

Shaft Speed : 1750 rpm

Outlet : 150mm, 6in

OUTPUT	HEAD	FLOW
5.5 kW	Rated : 12m, 39ft	Rated : 28.3 L/s, 449 gpm
7.5 HP	Max : 21m, 69ft	Max : 56.6 L/s, 898 gpm

Solid Passage : 76mm, 3in

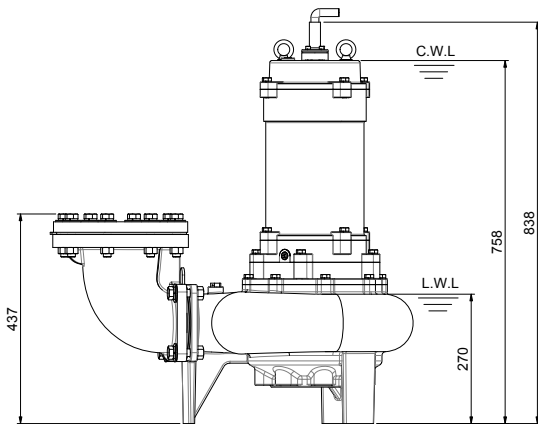
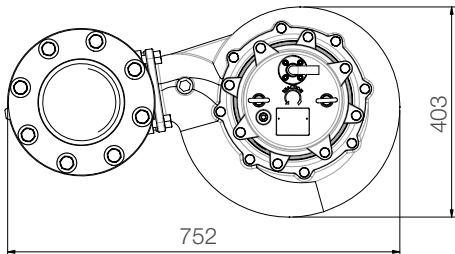

unit : mm

Weight : 138kg / 304 lbs

Pump Type	Electric Submersible Pumps		
	3-Phase		
Motor	Type	Induction Motor	
	Poles	4 Pole	
	Insulation	Class F	
	Protector	Star-Delta • Miniature Thermal Sensors	
		D.O.L. • Circle Thermal Protector	
Starter	Star-Delta , D.O.L.		
Lubricant	Food Grade (ISO VG32)		
Impeller Type	Single Channel		
Shaft Seal	Double Mechanical Seal		
	Silicon Carbide VS Ceramic / Carbon		
Bearings	C3 Shielded ball bearings		
Cable	PVC (CSA Certified) / H07RN-F		
	10m (33ft) or longer upon request.		
Materials	Pump Casing	Gray Iron	
	Impeller	Gray Iron	
	Motor Frame	Gray Iron	
	Motor Shaft	Stainless Steel	
	Mouth Ring	Copper Alloy	
Max. Liquid Temperature	40°C (104°F)		
Max. Submersion Depth	20m (66ft)		
pH Range	pH 5 - pH 8		
Guide Rail	GRN-04		